

Thank you for subscribing to SmarterScience Teacher Edition in 2025.

Key features of the Engineering Studies “2025 HSC Comprehensive Revision Series” include:

- ~16 hours of cherry-picked HSC revision questions by topic.
- Targeted at motivated students aiming for a Band 5 or 6 result.
- Weighting toward more difficult examples.
- Mark allocations given to each topic generally reflect its historical (new syllabus) HSC exam allocation.
- **Attempt, carefully review and annotate** this revision set in Term 3
- This question set provides the foundation of a concise and high quality revision resource for the run into the HSC exam.
- This resource should be used to complement (not replace) the critical final stretch preparation for every student - timed full exam practice papers.

Our analysis on each topic, the common question types, past areas of difficulty and recent HSC trends all combine to create this revision set that ensures students cover a wide cross-section of the key areas.

IMPORTANT: If students have been exposed to questions in these worksheets during the year, we say great. Many top performing students attest to the benefits of doing quality questions 2-3 times before the HSC. This type of revision set is aimed at creating confidence and *speed through the exam*, with cherry picked questions that cover all important elements of revision while avoiding low percentage rabbit hole excursions.

HSC Final Study: Telecommunications

- Electricity/Electronics (~9.0% historical contribution)

Key Areas addressed by this worksheet

- *Electricity/Electronics* is the largest contributing topic within the *Telecommunications* module, averaging over two longer response and two multiple-choice questions per year in the period 2020-24.
- *Radio transmission* is a focus area of the revision set, primarily due to its regular testing via multiple-choice and a couple of challenging longer answer questions in the 2019-2020 period (*2019 HSC 26b* is a “must review question”).
- *Television/Telephony* also features, having been the subject of longer answer questions in 4 of the last 6 exams (most recently in 2023). Questions require students to have a good understanding of antennae strength, 5G vs 4G networks and digital transmission.
- *Logic Gates/Circuits* is a critical revision topic, reflecting the fact it has been examined every year since 2017 in questions worth anywhere from 1-5 marks that typically test in the band 4-5 difficulty range.
- *Satellites* are a well-covered topic as they have appeared in the last 5 HSC exams. Revisions questions require that students have a solid understanding of the principles of GPS positioning and low orbit telecommunication systems. *2023 HSC 25c* and *2021 HSC 24c* are important revision questions in this context.
- *Circuits* were tested in the 2022-23 exams and are reviewed.

"The SmarterEd HSC exam preparation courses are incredible resources"

~ Peter Hargraves, James Sheahan Catholic High School

ENGINEERING 2025

HSC Revision Series

Telecommunications Engineering Electricity/Electronics

Exam Equivalent Time: 75 minutes (based on allocation of 1.5 minutes per mark)

Questions

1. ENGINEERING, TE 2016 HSC 9 MC

Which type of satellite is commonly used to broadcast TV signals?

- A. Low Earth-orbit satellite that orbits over the poles
- B. High Earth-orbit satellite that orbits over the poles
- C. Geostationary satellite that orbits above the equator
- D. Geosynchronous satellite that orbits above the Tropic of Capricorn

2. ENGINEERING, TE 2020 HSC 20 MC

Which of the following describes high frequency wireless transmission when compared to low frequency wireless transmission?

- A. Faster data rates over longer distances with higher interference
- B. Faster data rates over shorter distances with lower interference
- C. Slower data rates over longer distances with lower interference
- D. Slower data rates over shorter distances with higher interference



3. ENGINEERING, TE 2021 HSC 11 MC

Which radio transmission method is most likely to have static interference?

- A. Amplitude modulation (AM)
- B. Frequency modulation (FM)
- C. Digital audio broadcast (DAB)
- D. Pulse width modulation (PWM)

4. ENGINEERING, TE 2024 HSC 5 MC

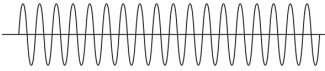
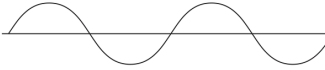
Which waveform diagram depicts an AM radio signal?

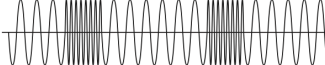
- A. 
- B. 
- C. 
- D. 

5. ENGINEERING, TE 2018 HSC 15 MC

Which of the following electronic circuits functions as a NAND logic gate?

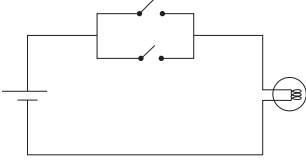
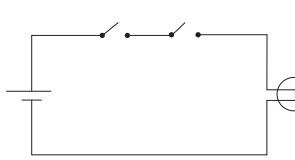
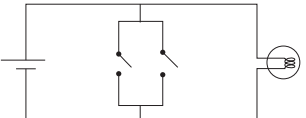
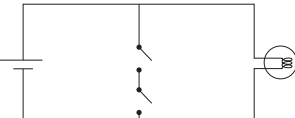
- A. 
- B. 
- C. 
- D. 

6. ENGINEERING, TE 2019 HSC 14 MC

Which row of the table correctly identifies key features of analogue and digital signals used in the transmission of television in Australia?

	<i>Analogue television signals</i>	<i>Digital television signals</i>
A.	FM signals used to transmit audio	MP2 or MP4 compression used to transmit video
B.	AM signals used to transmit audio	MP2 or MP4 compression used to transmit video
C.	FM signals used to transmit luminescence	VOIP used to transmit video
D.	AM signals used to transmit luminescence	VOIP used to transmit video

7. ENGINEERING, TE 2021 HSC 16 MC

The circuit diagram shown includes two transistors in its configuration.

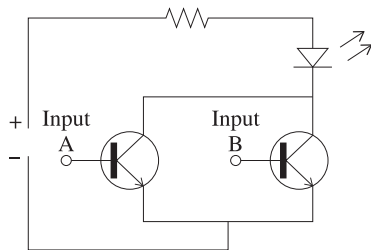

What type of logic gate has the same function as this pair of transistors in the circuit?

- A. OR gate
- B. NOR gate
- C. AND gate
- D. NAND gate

8. ENGINEERING, TE 2022 HSC 11 MC

A diode bridge is used to convert AC to DC current.

What type of conversion is this known as?

- A. Partial rectification
- B. Inverse rectification
- C. Full wave rectification
- D. Half wave rectification

9. ENGINEERING, TE 2022 HSC 13 MC

Four students (A, B, C, D) completed a table regarding the orbit of a GPS satellite.

Which student is correct?

	THE ORBIT OF A GPS SATELLITE	
	<i>Matches Earth's rotation?</i>	<i>Is above the equator?</i>
A.	Yes	Yes
B.	Yes	No
C.	No	No
D.	No	Yes

10. ENGINEERING, TE 2019 HSC 22b

A telecommunications engineer has designed a tower that is to support two mobile repeater transmitters. It is to be located in an urban community.

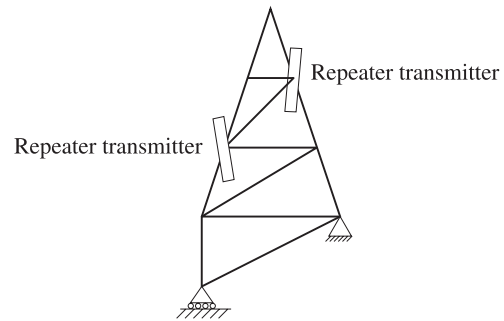

Explain why the engineer has positioned the repeater transmitters as indicated on the diagram. (3 marks)

.....

.....

.....

.....

.....

.....

.....

.....

11. ENGINEERING, TE 2020 HSC 21b

The diagram shows a simple logic circuit with inputs *A*, *B*, *C* and *D*, and output *Z*.

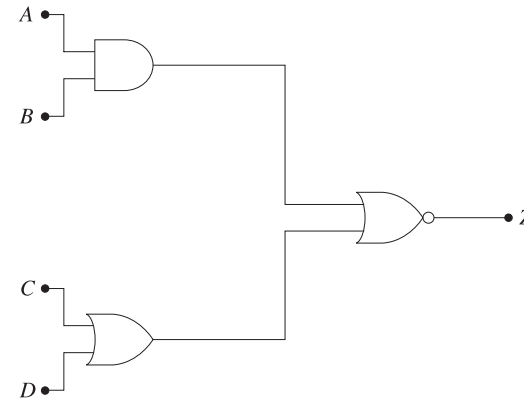

Inputs *A* and *D* are set to 'high' (1).

Determine, using the logic circuit diagram, the combination of inputs at *B* and *C* which will produce a high (1) output at *Z*. Use the truth table to support your answer. (3 marks)

<i>A</i>	<i>B</i>	<i>C</i>	<i>D</i>	<i>Z</i>
1				

.....

.....

12. ENGINEERING, TE 2020 HSC 26b

Outline benefits of digital signal transmission. (3 marks)

.....

.....

.....

.....

.....

.....

.....

.....

13. ENGINEERING, TE 2021 HSC 24a

A telecommunications engineer is designing a Wi-Fi network that will use either a 2.4 GHz or 5 GHz signal in a client's local area network.

How do the 2.4 GHz and 5 GHz signals differ in performance? (2 marks)

.....

.....

.....

.....

.....

.....

14. ENGINEERING, TE 2024 HSC 26b

To avoid overloading a cellular network, a logic gate is used to control the activation of a signal booster.

The signal booster will only activate when both of the following conditions are met:

- the signal strength falls below an acceptable level
- the network traffic flow falls below an acceptable level.

Complete a truth table for this scenario and identify a suitable logic gate. (3 marks)

Truth table:

<i>Acceptable signal strength</i>	<i>Acceptable traffic flow</i>	<i>Activate booster</i>

Logic gate:

17. ENGINEERING, TE 2020 HSC 26c

Discuss methods for increasing the signal strength of a receiving antenna. (3 marks)

.....

.....

.....

.....

.....

.....

.....

.....

.....

.....

18. ENGINEERING, TE 2021 HSC 24c

Describe the basic principles of low orbit satellite telecommunication systems. (3 marks)

.....

.....

.....

.....

.....

.....

.....

.....

.....

.....

19. ENGINEERING, TE 2022 HSC 22b

In the event of a fall or a medical emergency, smart watches are designed to alert emergency services when either of the following conditions is met.

Condition 1: the smart watch emergency alert is manually activated

Condition 2: the smart watch detects a sudden fall and no movement for 1 minute

An incomplete logic diagram showing the activation of the smart watch is given.

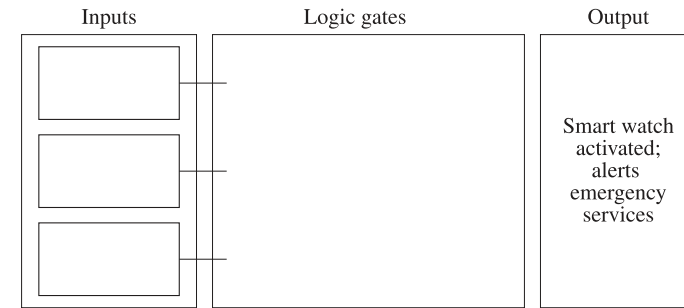

Complete the diagram by identifying the inputs and drawing the appropriate logic gates. (3 marks)

20. ENGINEERING, TE 2023 HSC 25c

Outline how GPS satellites determine a position on the planet. (2 marks)

.....

.....

.....

21. ENGINEERING, TE 2019 HSC 26b

A simple circuit diagram of the AM radio receiver is shown.

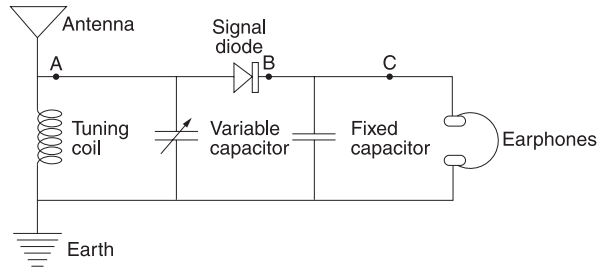

i. Complete the table giving the function of each of the circuit components listed. (5 marks)

Component	Function
Antenna	
Capacitor (fixed)	
Capacitor (variable)	
Earphones	Converts electrical signal to sound
Earth	
Signal diode	

ii. Complete the table by drawing the waveform at positions B and C. (2 marks)

Position	Waveform
A	
B	
C	

iii. This AM radio receiver produced a demodulated electrical signal with a small current. The speakers in the earphones converted this signal into sound.

Explain why the speakers in the earphones required a high impedance (resistance) in order to produce sound of sufficient volume to be heard. (2 marks)

.....

.....

.....

.....

.....

.....

.....

.....

Worked Solutions

1. ENGINEERING, TE 2016 HSC 9 MC

⇒ *D*

2. ENGINEERING, TE 2020 HSC 20 MC

- Higher frequency in wireless transmissions increases data rates
- However, it decreases wavelength which decreases the penetrating power of a transmission (ie the distance a transmission can travel).

⇒ *B*

3. ENGINEERING, TE 2021 HSC 11 MC

By Elimination:

- Digital broadcasting will have very little interference (eliminate *C* and *D*)
- The higher frequency of FM output results in less static than AM (eliminate *B*)

⇒ *A*

4. ENGINEERING, TE 2024 HSC 5 MC

- AM signals show clusters of varying frequency waves while maintaining a constant baseline frequency throughout the transmission.

⇒ *C*

5. ENGINEERING, TE 2018 HSC 15 MC

- NAND gates produce a high output (in this case turn the light on) as long as the 2 conditions are not BOTH met.

◆◆ Mean mark 34%.

- The gates in these diagrams represent inputs being met (closed) or not met (open).

- In *D*, if both gates close the circuit will be complete without turning the light on as 'both conditions have been met'.

⇒ *D*

Worked Solutions

6. ENGINEERING, TE 2019 HSC 14 MC

By Elimination:

- VOIP is used to transmit audio, not video (not *C* or *D*)
- FM signals are better for transmitting audio as they offer a higher fidelity than AM, creating a more accurate reproduction of the original sound (not *B*)

◆ Mean mark 42%.

⇒ *A*

7. ENGINEERING, TE 2021 HSC 16 MC

- If current/signal passes through A, B or both A & B, then the circuit is complete.
- This is the same requirements as an OR logic gate.

◆ Mean mark 41%.

⇒ *A*

8. ENGINEERING, TE 2022 HSC 11 MC

- If a diode bridge is used, the conversion will be full wave rectification.

◆◆ Mean mark 38%.

⇒ *C*

9. ENGINEERING, TE 2022 HSC 13 MC

By Elimination:

- GPS satellites need to cover most of earths surface, not just the equator, therefore not *A* or *D*.
- GPS satellites are in medium earth orbit and therefore are not geostationary (do not match earths rotation), so not *A* or *B*.

◆◆◆ Mean mark 24%.

⇒ *C*

10. ENGINEERING, TE 2019 HSC 22b

→ Transmitters are positioned on different stanchions at different levels so incoming signals produce minimal interference with each other.

→ The line-of-sight path of incoming and outgoing signals to the transmitter need to be considered.

Mean mark 58%.

11. ENGINEERING, TE 2020 HSC 21b

Let the output of the AND gate be E and the output of the OR gate be F

A	B	C	D	E	F	Z
1	1	0	1	1	1	0
1	1	1	1	1	1	0
1	0	1	1	0	1	0
1	0	0	1	0	1	0

→ As shown in the table, since D is always on, the output of the OR gate (F) will always be on/1.

→ Therefore, Z will always be 0 since it is a NOR gate, i.e. it requires E and F to be 0, and F is always 1.

→ Hence, there are no inputs at B and C that produce a high output at Z .

12. ENGINEERING, TE 2020 HSC 26b

Benefits of digital signal transmission include:

- Immunity to transmission noise and interference (clearer signal)
- Signal can be boosted or regenerated along the transmission path (reduced attenuation)
- Can be encrypted to be kept secure and private
- Signals can be processed and multiplexed (multiple messages can be sent along the same channel simultaneously)
- Error detection and correction is possible
- Cheaper than analogue transmission
- Signal can be compressed
- Signal can be stored and further processed

13. ENGINEERING, TE 2021 HSC 24a

→ 2.4 and 5 GHz signals differ in bandwidth, data transfer rate and attenuation (loss of signal strength).

→ A 2.4 GHz signal carries less data per second but suffers from less attenuation than a 5GHz signal.

→ 2.4GHz signals can also be transmitted through more/thicker obstacles.

14. ENGINEERING, TE 2024 HSC 26b

Truth table:

<i>Acceptable signal strength</i>	<i>Acceptable traffic flow</i>	<i>Activate booster</i>
1	1	0
1	0	0
0	1	0
0	0	1

Logic gate: NOR

15. ENGINEERING, TE 2023 HSC 23d

→ The diagram shows that 5G networks use shorter wavelengths and are subsequently on a higher frequency bandwidth than 4G networks.

→ The short wavelength means that the signal cannot travel as far as the signal in the 4G Network.

→ Given that there is shorter signal range and the signal cannot travel as far there needs to be antennae positioned closer together.

→ Since the antennae are closer together, they require more antennae to cover the same distances.

16. ENGINEERING, TE 2018 HSC 22c

Zener diode

- Voltage regulator.
- Allows current to flow above an assigned voltage (zener voltage).
- Stable reference voltage for a range of current values.

♦♦ Mean mark 39%.

Laser diode

- Focused light beam produced when current present in the circuit.
- Pulses of light transmitted down optical fibre, allowing transmission of digital data.

Light emitting diode

- When current present in the circuit a wide beam of light is emitted.
- Frequently used so show power is on.

17. ENGINEERING, TE 2020 HSC 26c

- Amplification: Amplifies the sound, however this could include unwanted background noise.
- Antenna tuning: The antenna can be tuned to the frequency of interest. This can be done by adjusting the length of the antenna, however this may not be practical in some scenarios.
- Directional antenna can focus the signal to increase strength however misalignment could result in losing the signal entirely.

Mean mark (c) 52%.

18. ENGINEERING, TE 2021 HSC 24c

Successful answers would cover one of the following:

Low orbit Satellites

- Low orbit satellites orbit the earth at altitudes below 2000 km.
- Low orbit telecommunication systems have many satellites that pass overhead as these satellites are not geostationary and move in and out of range of the handset.
- These satellites take around 90 minutes to orbit earth and are only in range for 5 minutes maximum.
- When one satellite is about to disappear from the reception range, another comes into range and takes over communication.

♦ Mean mark 49%.

Satellite telephones

- Satellite telephones broadcast their individual ID numbers to satellites to identify which are in range.
- Once a satellite receives the signal it is passed onto a base station, then its destination.
- The phone signal is passed between satellites until one in contact with the base station is in range.
- The phone signal is modulated using phase shift keying due to long transmission distances.

19. ENGINEERING, TE 2022 HSC 22b

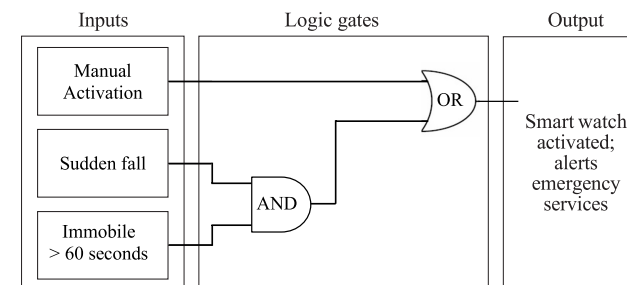

Mean mark 54%.

20. ENGINEERING, TE 2023 HSC 25c

- Position is determined when a GPS satellites triangulate signals.
- Triangulation depends on the accurate measurement of the time differences between signals traveling from satellites to GPS receivers.

◆ Mean mark 44%.

21. ENGINEERING, TE 2019 HSC 26b

i.

<i>Component</i>	<i>Function</i>
Antenna	Receives the electromagnetic signal and feeds it into the circuit
Capacitor (fixed)	Smooths out rectified signal and creates a demodulated waveform
Capacitor (variable)	The coil works together with the variable capacitor so the circuit will resonate at one frequency. Therefore, enabling a single frequency to be detected rather than all possible frequencies.
Earphones	Converts electrical signal to sound
Earth	Provides a negative pole for the circuit
Signal diode	Allows for only positive current to flow through the circuit, converting the signal received into a waveform capable of being rectified (half-waveform)

◆ Mean mark (i) 47%.

ii.

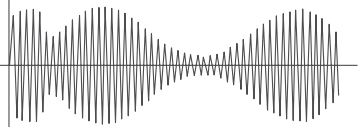
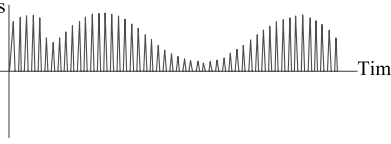
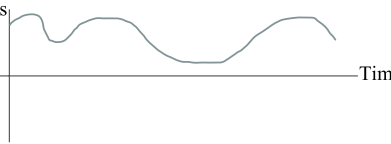
<i>Position</i>	<i>Waveform</i>
A	
B	
C	

◆◆ Mean mark (ii) 22%.

iii. → An external power source is not used to power this radio.

→ The signal picked up by the aerial powers the speakers.

→ If the impedance (resistance) is high an audible signal can be generated by the speaker at a low current.

→ Because the earphone impedance is high, the sensitivity of the coil improves, resulting in a more accurately tuned signal.

◆◆ Mean mark (iii) 15%.

→ The sound would be inaudible if the impedance is low, as the power to the earpiece would also be low.